

BUSINESS PROCESS IMPROVEMENT PLAN IN OPERATIONAL LEAD TIME CONTROL OF SPAREPART BY OPTIMIZING DIGITAL TOOL AND DEALING WITH VENDOR IN PT TACI

Widhi Wahyuniarti^{1*}, Anton Mulyono Azis^{2*}

¹Faculty of Economics and Business, Telkom University, Bandung, Indonesia

²Faculty of Economics and Business, Telkom University, Bandung, Indonesia

Corresponding Email: *widhiti07@gmail.com, *antonmulyono@telkomuniversity.ac.id

Received : 22 June 2025

Revised : 30 June 2025

Accepted : 17 July 2025

Published : 28 August 2025

DOI : <https://doi.org/10.54443/ijevas.v5i4.3758>

Link Publish : <https://radjapublika.com/index.php/IJEBAJ>

Abstract

The manufacturing industry, particularly the automotive sector, faces significant challenges in managing lead time for spare parts procurement, which impacts operational efficiency and cost-effectiveness. PT TACI, a company specializing in compressor production for vehicle air conditioning systems, encounters delay in the spare parts procurement process, affecting its production schedule. The purpose of this research is to analyze and improve the spare part procurement and operational lead time control processes at PT TACI. The study identifies barriers in the current processes, especially those related to technology, web integration, and supplier agreements. A qualitative approach was employed, consisting of in-depth interviews, focus group discussions, and direct observations with key personnel in PT TACI's Part Tool Inventory Control (PTIC) department. The findings reveal that delays primarily arise from manual approval processes, inefficient data integration between IMS and EPS systems, and inconsistent supplier performance. The research also emphasizes the role of digital technology, particularly web-based integration and supplier agreements, in enhancing procurement efficiency. Based on Business Process Improvement (BPI) principles, this study proposes a set of recommendations, including the automation of the approval process, real-time system integration, improved supplier collaboration, and the simplification of routine procurement processes. The implications of this research suggest that digital system optimization and stronger supplier relationships can significantly reduce lead times and improve operational performance. Future research could explore advanced technologies like AI or Blockchain for further procurement process optimization.

Keywords: *Spare parts; Procurement process; Lead time; Business Process Improvement (BPI); Web integration*

Introduction

The manufacturing industry, particularly in the automotive sector, plays a vital role in the global economy. Companies in this sector face significant challenges in managing operations efficiently, one of which involves controlling lead time in the procurement of raw materials and spare parts. Prolonged lead times may cause production delays, disrupt on-time delivery to customers, and increase operational costs. Therefore, efficient lead time management is a crucial factor for achieving competitive advantage in the marketplace. According to Utomo et al., (2021), effective lead time control is directly related to improving production effectiveness, which is essential for maintaining market competitiveness. One company facing notable challenges in spare part procurement is PT TD Automotive Compressor Indonesia (PT TACI), which manufactures air conditioning compressors for vehicles. PT TACI supplies its products to major automotive companies both in Indonesia and globally. The company envisions being a trusted partner to its customers through pillars of operational excellence, including defect-free quality, on-time delivery, and highly efficient production. Among the key factors contributing to this vision is timely and integrated spare part procurement to support uninterrupted production and meet customer demand. Delays in spare part procurement can disrupt production flows, cause machinery downtime, reduce production capacity, and elevate operational costs. Prior studies have demonstrated that delays not only affect production efficiency but also result in additional expenses, such as express delivery and overtime costs (Sutjiatmo et al., 2024). Furthermore, delays have

BUSINESS PROCESS IMPROVEMENT PLAN IN OPERATIONAL LEAD TIME CONTROL OF SPAREPART BY OPTIMIZING DIGITAL TOOL AND DEALING WITH VENDOR IN PT TACI

Widhi Wahyuniarti and Anton Mulyono Azis

been shown to impact production lines and increase total operational costs, potentially leading to late product shipments (Andrašec et al., 2024). Inability to manage lead time may also damage the company's reputation among customers who expect timely delivery as promised (Tiedemann et al., 2021). At PT TACI, spare part procurement is managed by the Part Tool Inventory Control (PTIC) department, which is responsible for ensuring the timely availability of parts necessary for maintenance and machine repair. Effective management of procurement lead time is therefore essential for maintaining seamless production and delivery. Although PT TACI has implemented two information technology systems Inventory Management System (IMS) and Electronic Procurement System (EPS) the company continues to face significant challenges. The IMS is designed to manage spare part inventory efficiently, by recommending reorder points and optimizing purchases based on historical usage and supplier lead times. EPS, on the other hand, is used to expedite purchasing and procurement activities, offering improved efficiency and transparency in product selection, ordering, delivery, and payment processes. Despite these systems being in place, challenges persist, including supplier stock uncertainties, poor information flow between procurement and production departments, and limitations in real-time monitoring capabilities. Pradnyana & Listartha, (2021) note that existing procurement systems often fail to adequately support effective lead time control and require further enhancement and integration with more robust technologies. Business Process Improvement (BPI) is a method used to analyze and enhance the efficiency and effectiveness of business processes. BPI aims not only to improve operational efficiency but also to reduce waste, accelerate cycle times, and optimize resource utilization (Andrašec et al., 2024). Within the context of PT TACI, implementing appropriate BPI techniques can help identify procurement lead time issues and provide technology-based solutions to address them.

Previous research by Andrašec et al., (2024) highlights various techniques and methods used in BPI to improve operational processes, particularly in controlling lead time. These techniques involve systematic analysis and technological application to improve information flow and time management. This approach aligns closely with PT TACI's need to enhance its lead time control systems through more efficient digital tools. Additionally, Pradnyana & Listartha, (2021) emphasize the importance of integrating stronger systems to optimize procurement and reduce inefficiencies. Their study shows that implementing technology-based BPI can address key challenges, especially those arising from unintegrated information across systems. Strengthening existing systems at PT TACI by deploying technology-driven BPI is therefore expected to improve spare part procurement processes and expedite production flow. Junaidi et al., (2024) also note the importance of automated monitoring systems in reducing procurement delays and ensuring timely decision-making in addressing procurement issues. Without such automation, decisions are often delayed, leading to disruptions in production schedules. Therefore, implementing real-time monitoring systems is crucial to detect delays promptly and enable rapid corrective actions. Research by Babičković et al., (2020) on SCADA system implementation in the waste treatment industry demonstrates how automation technology can improve efficiency and reduce system failure risks. PT TACI could adopt a similar approach by integrating a web-based monitoring system to oversee the entire spare part procurement process from initial requests to final delivery including supplier communications.

In addition to digital optimization, stronger collaboration with suppliers is a key focus of this research. Gebisa, (2023) illustrates that effective information sharing practices between firms and suppliers can enhance supply chain performance and reduce operational costs. Leveraging API-based technology to enable direct information exchange between PT TACI and its suppliers would increase transparency in spare part procurement and minimize delays. Adirektawon et al., (2024) also highlight the benefits of Vendor-Managed Inventory (VMI) in improving efficiency by reducing inventory management costs and enhancing turnover rates. Closer collaboration with suppliers through VMI or integrated systems can help PT TACI access more accurate inventory data, facilitating faster and more precise decision-making. This study aims to address gaps in lead time management for spare part procurement at PT TACI by applying Business Process Improvement, optimizing digital tools, and enhancing supplier engagement. Although prior studies emphasize the importance of information systems in improving efficiency and reducing lead times, notable gaps remain in real-time monitoring capabilities and transparent supplier collaboration. This research focuses on the implementation of advanced technologies and integrated systems to ensure that procurement delays are detected early and preventive actions are taken before they impact production.

Literature review

Operations Management Theory and Business Processes

Operations management is an interdisciplinary domain that combines both art and science to design, direct, and control processes that transform inputs into outputs in the form of goods or services for internal and external customers. It plays a pivotal role in ensuring that products and services are produced and delivered effectively (Collier & Evans, 2021). Business processes, as an integral part of operations management, are defined as a series of activities

BUSINESS PROCESS IMPROVEMENT PLAN IN OPERATIONAL LEAD TIME CONTROL OF SPAREPART BY OPTIMIZING DIGITAL TOOL AND DEALING WITH VENDOR IN PT TACI

Widhi Wahyuniarti and Anton Mulyono Azis

that convert inputs into value-added outputs for customers and stakeholders (Krajewski & Malhotra, 2022). The efficiency and effectiveness of these processes strongly influence the quality and cost of the resulting goods and services (Sukmono, 2021). Fragmented or poorly coordinated processes can reduce productivity and degrade organizational performance. Hence, the implementation of Business Process Improvement (BPI) is essential. Research by Andrašć et al., (2024) suggests that appropriate BPI methods can significantly improve business processes, including spare part procurement and management, which are the focus of this study. Similarly, Pradnyana & Listartha, (2021) indicate that applying BPI to information systems can result in more efficient processes, particularly through simulation-based technological solutions.

Business Process Improvement (BPI) Theory

Business Process Improvement (BPI) is a systematic methodology designed to enhance the effectiveness and efficiency of organizational operations by eliminating wasteful practices and improving process outcomes (Utomo et al., 2021). BPI efforts focus on streamlining workflows, reducing costs, and improving customer satisfaction, all of which contribute to achieving long-term business objectives. The BPI approach consists of five interrelated phases (Harrington, 1991; Pradnyana & Listartha, 2021). Organizing for Improvement, Understanding the Process (As-Is), Streamlining the Process, Measurement and Control, and Continuous Improvement. The first phase involves analyzing existing processes and identifying areas requiring immediate attention through interviews and internal discussions. In a study by Immawan, (2021), the five BPI phases were applied using tools such as Value Stream Mapping (VSM) and Economic Value Added (EVA), which helped identify non-value-added activities and optimize workflows for greater efficiency.

Supply Chain Management (SCM) Theory

Supply Chain Management (SCM) is a multidisciplinary framework that coordinates activities involved in the production and distribution of goods and services. SCM ensures that materials, information, and financial flows are seamlessly integrated among all internal and external stakeholders to optimize value creation and minimize waste (Krajewska & Krajewski, 2020). A well-managed supply chain heavily depends on inbound logistics, which includes managing the delivery of materials and spare parts from suppliers to warehouses to support production. Syamil et al., (2023) underscore that effective coordination across supply chain entities is crucial to avoid operational inefficiencies and data discrepancies that could increase costs. Studies by Babičković et al., (2020) and Adirektawon et al., (2024) focusing on supply chain digitalization and the use of web-based systems are aligned with this research, particularly in enhancing information flow and delivery time control in spare part procurement through the implementation of technologies such as IMS and EPS.

Lead Time Management in Supply Chains

Lead time management is a strategic component in supply chain optimization, referring to the duration required to complete a process from ordering to final delivery (Sirine, 2024). Efficient lead time management is crucial for reducing operational bottlenecks, improving service quality, and enhancing customer satisfaction. Chengguo et al., (2021) found that effective lead time management enhances market responsiveness and reduces operational costs through technological automation and monitoring. This aligns with findings from Gebisa (2023), who demonstrated that digital information integration in the supply chain improves efficiency and lowers operational expenditures. Just-in-Time (JIT) approaches, which prioritize procurement when needed, and the utilization of real-time monitoring technologies—as recommended by Immawan, (2021) offer strategic advantages in minimizing lead time and optimizing inventory control.

Digital Supply Chains and Integrated Web Systems

Digital transformation in supply chain management marks a significant paradigm shift from manual systems to data-driven ecosystems. Through the implementation of web-based platforms, organizations can enhance real-time communication, automate workflows, and reduce reliance on paper-based documentation. Irmayani et al., (2022) affirm that digital platforms improve transparency, reduce lead times, and enhance data accuracy for purchasing, ordering, and inventory management decisions. These findings are consistent with Prasetio & Muchnita, (2022), who emphasize the importance of integrated web-based systems in improving operational transparency and flexibility. Moreover, emerging technologies such as Blockchain and Internet of Things (IoT) offer full visibility into product flows, empowering organizations to respond swiftly to demand fluctuations and emergency scenarios (Alamsyah et al., 2022). Technology can have a positive or negative impact on a company, depending on how it is used to improve efficiency and effectiveness in serving customers (Hendayani & Febrianta, 2020). Therefore, to maximize the benefits

BUSINESS PROCESS IMPROVEMENT PLAN IN OPERATIONAL LEAD TIME CONTROL OF SPAREPART BY OPTIMIZING DIGITAL TOOL AND DEALING WITH VENDOR IN PT TACI

Widhi Wahyuniarti and Anton Mulyono Azis

of web integration technology and ensure complete customer satisfaction, full transparency is required throughout the supply chain network.

Supplier Agreements

Supplier agreements form the legal and operational foundation for effective buyer-supplier relationships. These contracts define expectations around price, product quality, delivery schedules, quantities, and compliance requirements. Research by Yan et al., (2025) indicates that clearly defined supplier agreements reduce uncertainty and enhance supply chain efficiency. This is further supported by Monczka et al. (2015 in Saragih, 2024), who emphasize that well-crafted contracts strengthen supply chain reliability and foster better collaboration between parties. Implementing robust agreements enables companies to secure timely deliveries, reduce risks, and build stronger supplier relationships. Saragih, (2024) adds that supplier contracts serve as essential tools for mitigating procurement risks and ensuring the continuity of material supply. In implementing a supplier selection contract, good communication between the company and the supplier is crucial. Both parties must understand each other and work together to ensure the contract is executed properly. Companies must also be flexible and responsive to potential changes in the business environment or contract requirements. By properly executing supplier selection contracts, companies can ensure that their supplier relationships run smoothly and align with their supply chain objectives (Saragih, 2024, p. 143).

Research method

This study employs a qualitative approach to explore the spare part procurement process and lead time management at PT TD Automotive Compressor Indonesia (PT TACI). Data was collected through a combination of in-depth interviews, focus group discussions (FGDs), and direct observations, which were designed to provide a comprehensive understanding of the challenges and practices within the procurement system (Sholihah et al., 2023). The research focuses on the actors involved in the spare part procurement process, including supervisors, foremen, and staff members from the Part Tool Inventory Control (PTIC) department, who were selected using a purposive sampling technique. The study is conducted at PT TACI's operational facility in Cikarang Barat, Bekasi, Indonesia, over a period of two months (April-May 2025). The data collection instruments include structured interview guides developed from the research objectives and theoretical framework, tested with a few preliminary respondents for clarity and relevance. The company's procurement logs and performance data were also reviewed to complement the findings from the interviews and FGDs. The data analysis follows Miles and Huberman's interactive model, which involves three stages: data reduction, data display, and conclusion drawing/verification (Pasaribu et al., 2022).

Results

Characteristics of Informants and Descriptive Data

These informants will undergo in-depth interviews, and the validity of the data will be verified through a focus group discussion.

Table 1. *Characteristics of Informants*

Informant Code	Position	Work Experience	Reason for Selection
SPV1	SPV PTIC 1	10 years	Knowledgeable about the process, obstacles, digital systems, and supplier relations.
SPV2	SPV PTIC 2	10 years	Same as SPV1
FRM1	Foreman PTIC 1	20 years	Provides technical support, controls ordering process, manages warehouse and suppliers.
STF1	Staff PTIC 1	12 years	Handles spare parts orders, administrative support, and communicates with suppliers.

Source: PT TACI, Primary Data Processed (2025)

In addition to conducting in-depth interviews with the informants, which will be verified through a focus group discussion, some of the results from the in-depth interviews will also be cross-checked with other sources through

BUSINESS PROCESS IMPROVEMENT PLAN IN OPERATIONAL LEAD TIME CONTROL OF SPAREPART BY OPTIMIZING DIGITAL TOOL AND DEALING WITH VENDOR IN PT TACI

Widhi Wahyuniarti and Anton Mulyono Azis

observations and supporting documents, including screenshots of activities and system/internal report displays from PTIC members

Spare Parts Procurement and Control Process at PT TACI

Spare Parts Procurement Flow

The spare parts procurement process at PT TACI begins with the detection of stock reaching the Order Point (OP) via the IMS system. If the stock falls below the OP, the system automatically triggers the creation of a Purchase Request (PR) by the PTIC team. The PR is then processed in the EPS system for internal approval, involving various levels (SPV, Manager, GM, Director, and VP). The standard time targeted for this approval process is 14 days.

Figure 2

Average Internal Approval Time (Days)

[MONTHLY INFORMATION] PERFORMANCE INTERNAL APPROVAL...



Dear all,
Selamat pagi

Berikut saya kirimkan lampiran Performance Internal Approval EPS PTIC (Monthly). Sebagai bahan evaluasi agar tidak terjadinya Delay Approval. Untuk data lebih lengkap silahkan cek di link berikut

Link :

[\\tacifss02\t5200\\$\R_Inventory\03_FY24\1_Reduce Inventory\Mevi\Performance Internal Approval EPS PTIC\FY 2024\07_Performance Internal Approval EPS PTIC \(Februari 2025\).xlsx](\\tacifss02\t5200$\R_Inventory\03_FY24\1_Reduce Inventory\Mevi\Performance Internal Approval EPS PTIC\FY 2024\07_Performance Internal Approval EPS PTIC (Februari 2025).xlsx)

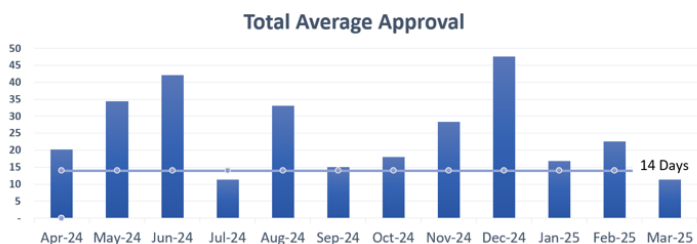

Source: PT TACI, Primary Data Processed (2025)

Based on Figure 3, the approval process should be completed within 14 days. However, data in Appendix Slide 2 show that the average lead time exceeds the target due to the lengthy approval process. Below is the flowchart illustrating the overall spare parts procurement process:

Figure 3

Spare Parts Procurement Process Flowchart

BUSINESS PROCESS IMPROVEMENT PLAN IN OPERATIONAL LEAD TIME CONTROL OF SPAREPART BY OPTIMIZING DIGITAL TOOL AND DEALING WITH VENDOR IN PT TACI

Widhi Wahyuniarti and Anton Mulyono Azis

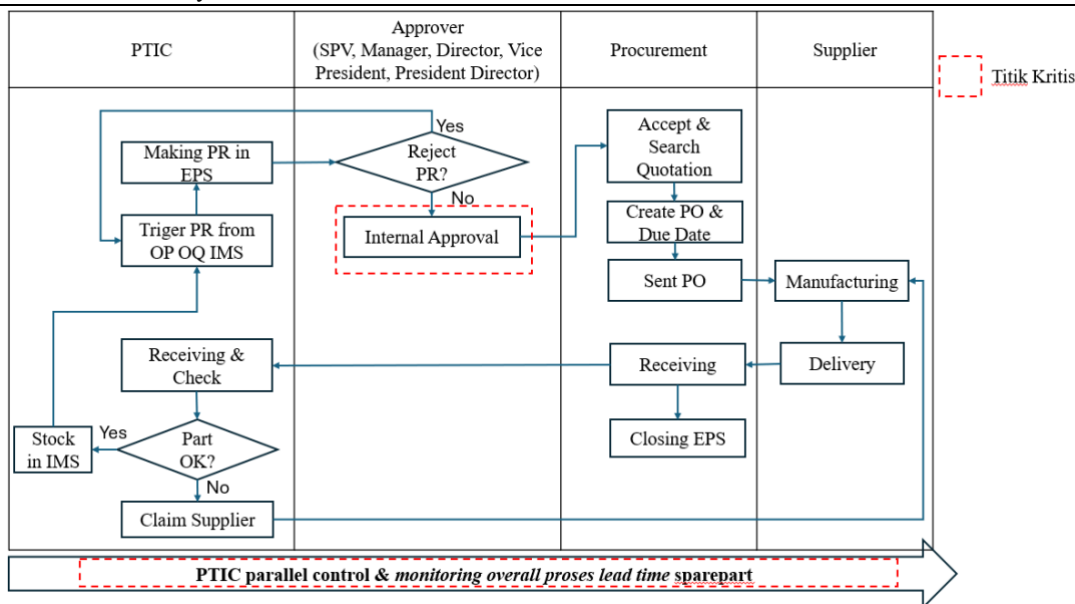

Source: PT TACI, Primary Data Processed (2025)

Interviews with SPV1 (June 5, 2025) revealed persistent challenges in the internal approval stage, where multi-level approvals often exceed the two-week target due to high workloads among Managers and GMs. Despite SPV1's manual follow-ups via email and direct communication, delays remain unresolved. An automated system with notifications and stricter time limits was suggested to streamline the process. Similarly, FRM (June 10, 2025) emphasized the importance of controlling critical stock. Each week, the PTIC team manually extracts data from IMS to monitor urgent items and communicates this via email to relevant parties. These manual tasks often lead to delays. FRM proposed stronger integration between IMS and EPS to enhance stock visibility and decision-making speed. SPV2 (June 17, 2025) reinforced concerns about internal approvals, noting that email reminders are frequently ignored by superiors. SPV2 recommended improving real-time tracking and automated alerts through tighter IMS–EPS integration. Although PT TACI's spare part procurement system is structurally sound, its internal approval mechanism remains the main bottleneck. As SPV1 and FGD participants (June 20, 2025) observed, manual reminders are insufficient, and integration between IMS and EPS does not yet mitigate delay risks effectively. Findings suggest that excessive approval layers and manual systems hinder procurement speed, pushing lead times beyond target. Interviewees advocate for automated notifications and system integration to support real-time monitoring, improve transparency, and accelerate internal approvals—essential for operational continuity.

Procurement Control to Maintain Lead Time

Control over lead time begins with the internal approval process, which influences the speed of order placement. This process involves multiple approval levels, from the supervisor (SPV) to the manager and director. SPV1 (June 5, 2025) explained that lead time control is often hindered by the numerous approval levels and the large number of PRs that need approval. Despite the reminders, delays arise when there are too many approvals, especially for routine items that are frequently ordered. As a result, although the target is two weeks, the actual approval time often exceeds one month.

Figure 4

Procurement and Critical Spare Parts Progress Control Flowchart PTIC

BUSINESS PROCESS IMPROVEMENT PLAN IN OPERATIONAL LEAD TIME CONTROL OF SPAREPART BY OPTIMIZING DIGITAL TOOL AND DEALING WITH VENDOR IN PT TACI

Widhi Wahyuniarti and Anton Mulyono Azis

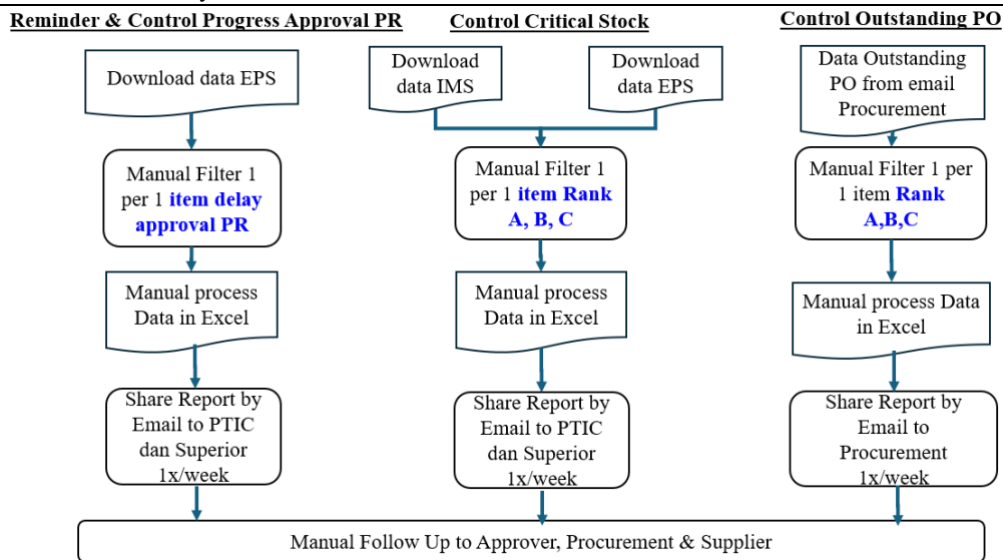

Source: PT TACI, Secondary Data Processed (2025)

The flowchart above illustrates three main processes in procurement and inventory control at PT TACI. The first process, Outstanding PO Control, involves manually processing data from purchase orders (POs) received via email based on priority categories (Rank A, B, C), then visualizing it in a graph and reporting it to the Procurement team. The second process, Critical Stock Control, downloads data from the IMS, filters priority items (Rank A, B, C), and then visualizes it in a graph and reports it to the PTIC and superiors. The final process, Approval Progress Reminder & Control, downloads data from the EPS, manually identifies late approvals, visualizes it in a graph, and reports it to the PTIC and superiors. Follow-up is carried out to ensure timely approvals from authorized parties, the procurement team, and suppliers.

Critical Stock Control and Urgency Checking

Critical Stock Control at PTIC, as explained by the FRM (June 10, 2025), uses data from the IMS to monitor running low and prioritize procurement based on urgency. These items are divided into three categories: Rank A, which are urgent items that require immediate sourcing; Rank B, which have low urgency; and Rank C, which, although critical, are rarely used. The primary focus is on controlling Rank A and Rank B items to ensure smooth production, as delays in their procurement can disrupt the production line. The FGD results (June 20, 2025) indicated that although the IMS and EPS systems are connected, urgency control is still suboptimal due to limited integration between the two systems. This results in the inability to directly access urgency information through the EPS, leaving approvers with insufficient data to prioritize items appropriately. Therefore, improved integration between the two systems is needed to improve procurement efficiency. According to the STF and SPV2 (June 17, 2025), although product quality inspection procedures have been implemented in the warehouse, products often do not meet established standards. This results in additional verification, which slows down the goods receiving process and disrupts inventory control. To improve spare parts procurement and lead time control, it is recommended to improve integration between the IMS and EPS systems, implement automated reminders to expedite the approval process, and tighten product quality inspection procedures, both at the supplier level and internally.

Barriers that Cause Spare Part Procurement Lead Time to Become Suboptimal

Efficiency in managing spare part procurement lead time is critical to ensuring smooth operations and preventing production downtime. However, findings from the field indicate various barriers that prevent the spare part procurement process at PT TACI from running optimally. These barriers were identified through a series of interviews with relevant parties and focus group discussions (FGD). The majority of the issues arise from complex internal processes, as well as reliance on manual systems that slow down the procurement flow. Based on interviews with SPV1 (June 5, 2025), SPV2 (June 17, 2025), FRM (June 10, 2025), STF (June 18, 2025), and the FGD held on

June 20, 2025, seven main barriers were identified that disrupt the efficiency of spare part procurement. The following explanation provides an analysis of these barriers with relevant visual evidence.

Lengthy Internal Approval Process

One of the biggest barriers identified in the spare part procurement process is the lengthy internal approval process. During an interview with SPV1, it was explained that the approval process, which involves seven levels of approval, causes significant delays. At Approver-4, there are 112 pending Purchase Requests (PR), with 20 of them exceeding the seven-day deadline. FRM added that although the expected approval time is two weeks, in reality, this process can take up to one month, primarily due to overload at the approver level and the absence of an automatic escalation system to speed up the approval process.

Figure 5
Total Waiting Graph

BUSINESS PROCESS IMPROVEMENT PLAN IN OPERATIONAL LEAD TIME CONTROL OF SPAREPART BY OPTIMIZING DIGITAL TOOL AND DEALING WITH VENDOR IN PT TACI

Widhi Wahyuniarti and Anton Mulyono Azis

[WEEKLY INFORMATION] REMINDER APPROVAL EPS PTIC [05/05/20...



5/5/2025

Dear all,

Here we share regarding PR PTIC need approved soon in order to maintain and fulfil stock needed,

Please check list PR no. below in each approver name, then click PR no. to check and approved soon.

Link : [\\tacifss02\t5200\\$\R. Inventory\03_FY24\1. Reduce Inventory\Mevi\Reminder Approval EPS PTIC\FY 2025\02. MEI 2025\1. Reminder Progress Approval Internal EPS PTIC \(05 Mei 2025\).xlsx](#)

GRAPH TOTAL WAITING

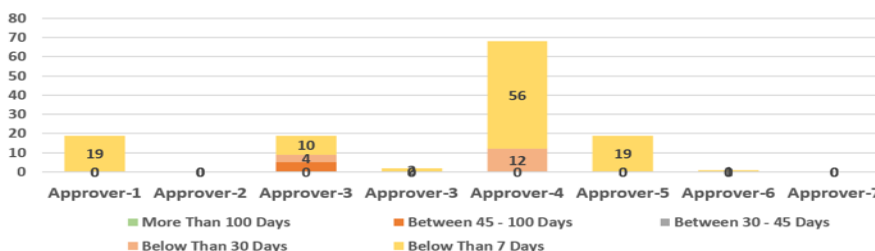

Source: PT TACI, Secondary Data Processed (2025)

The graph above shows the distribution of PR delays based on the approver level, with the largest accumulation occurring at Approver-4, which becomes the bottleneck in the procurement process. This affects the overall lead time. As a solution, it is recommended to implement auto-approval for routine PRs that have been in the system for more than 14 days without approval to speed up the approval flow, especially for frequently requested items that are not complex.

Dependence on Manual Reminders

STF, in an interview on June 18, 2025, revealed that weekly email reminders sent to superiors are ineffective because they lack urgency indicators. The email only contains a list of PRs without information on priority, forcing the approver to open the attached Excel file to verify the PR’s priority level. This slows down the process of identifying and addressing urgent PRs. SPV1 also mentioned that the reminders provided do not include urgency classification, further exacerbating the inefficiency of the reminders.

Figure 6

Email Reminder

[WEEKLY INFORMATION] REMINDER APPROVAL EPS PTIC [19/05/2025]

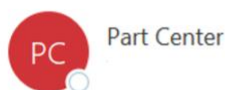

5/19/2025

Dear all,

Here we share regarding PR PTIC need approved soon in order to maintain and fulfil stock needed,

Please check list PR no. below in each approver name, then click PR no. to check and approved soon.

Link : [\\tacifss02\t5200\\$\R.Inventory\03_FY24\1.Reduce Inventory\Mevi\Reminder Approval EPS PTIC\FY 2025\02. MEI 2025\5. Reminder Progress Approval Internal EPS PTIC \(19 Mei 2025\).xlsx](#)

Source: PT TACI, secondary data processed (2025)

The figure above shows the email reminder template that only lists PRs without urgency classification. This simple template does not provide enough information to help the approver prioritize their tasks. Therefore, it is proposed to create a more structured automatic reminder system that includes priority indicators, such as coloring critical PRs (red) or those with high priority (yellow). With a clear visualization of urgency levels, it is hoped that reminders will become more effective.

Data Inconsistency between IMS and EPS

FRM, in an interview on June 10, 2025, revealed that stock data in the IMS is often not updated in real-time in the EPS, causing discrepancies between the stock status in both systems. For example, even though stock items are depleted in IMS, they still appear as available in EPS, leading to erroneous procurement decisions. SPV2 also added that the PR quantity in EPS can be manually modified, whereas the data should follow the OP/OQ from IMS to maintain accuracy. This data inconsistency increases the risk of procurement errors and worsens lead time. The unavailability of real-time stock information in EPS causes errors in procurement decision-making. Therefore, better integration between IMS and EPS is necessary so that updated stock information can be accessed directly by the approver on a single interface. Implementing an API to enable real-time data synchronization will minimize procurement errors and expedite the approval process.

Supplier Delays

SPV1, in an interview on June 5, 2025, revealed that delays in delivery often occur due to emergency requests submitted via email before the Purchase Order (PO) is approved. These requests create a deadlock in the procurement process because the supplier will only process the items after the PO is issued. STF also added that the supplier's production lead time, which can reach one to two months, often causes the procurement process to take longer than expected. The image above shows an emergency shipment request for the item "RING PLUNGER TIP 0301-048-1" before the PO is approved. These emergency requests that bypass the formal process cause discrepancies between the procurement schedule and supplier readiness. To smoothen the procurement process, system integration with suppliers should be implemented to allow real-time stock updates and more accurate forecasting, reducing reliance on manual reminders and speeding up the shipping process.

Human Resource Limitations and Manual Workload and Lack of System Integration

FRM, during the FGD on June 20, 2025, stated that about 70% of the procurement team's time is spent inputting data manually using Excel and following up verbally with various parties. SPV2 also revealed that to manage critical stock, the team must filter data one by one in Excel, which is time-consuming and labor-intensive. The lack of integration between IMS and EPS results in inefficiency in the approval process and decision-making. FRM highlighted that approvers cannot access real-time stock data in EPS, so approval decisions cannot consider urgency or the availability of items in the warehouse. SPV2 also emphasized that to review the status of a single item, staff must manually open two separate systems, which increases the risk of communication errors and delays.

Figure 8
Flow Process Before (As Is)

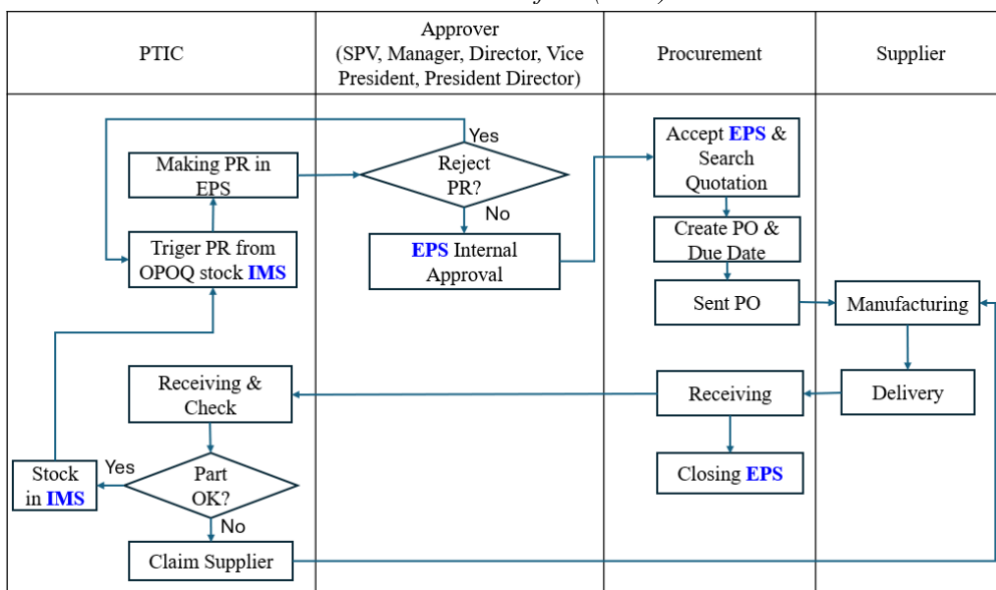

Source: PT TACI, secondary data processed (2025)

This fragmented flow leads to inefficiencies and adds time to the approval process. The proposed solution is to integrate the IMS and EPS systems into a centralized dashboard, where approvers can view stock status and PRs in a single view, making decision-making faster and more accurate.

Manual Forecasting and Emergency Shipments

STF, in an interview on June 18, 2025, mentioned that forecasting is often done manually through Excel emails, which is highly susceptible to human error. SPV1 also added that emergency shipment requests before PO approval lead to stock that does not match current needs. Observations showed that manual forecasting in Excel format is sent to suppliers via email. This process is prone to data input errors and format inconsistencies. The recommended solution is to digitalize the forecasting process and use standardized templates to reduce human error and increase accuracy.

The Role of Digital Technology Utilization (Web Integration) and Supplier Agreements in Procurement Process Efficiency

The utilization of digital technology, particularly web integration in procurement systems, plays a crucial role in enhancing the efficiency of spare parts procurement at PT TACI. Additionally, the role of supplier agreements is a key factor in optimizing time and procurement costs. The following analysis is based on interviews and focus group discussions (FGD) conducted.

Utilization of Digital Technology in Spare Parts Procurement

PT TACI uses two main digital systems in the spare parts procurement process, namely the Inventory Management System (IMS) and the Electronic Procurement System (EPS). The IMS is used to control stock levels and provide notifications when stock reaches the minimum level (Order Point - OP). This system also provides information on the quantity of items to be ordered according to the predetermined Order Quantity (OQ). On the other hand, EPS facilitates the creation of Purchase Requests (PR), obtaining internal approvals, and creating Purchase Orders (PO) to be sent to suppliers. Although these systems are integrated to support procurement, several issues were found related to the seamless integration between IMS and EPS. One key issue is the discrepancy in data between IMS and EPS, particularly in stock information that is not always updated automatically. This discrepancy causes delays in the PO approval process due to data inconsistencies between the two systems.

The FGD results indicate that while integration between IMS and EPS is present, there is a need for improvements in data visualization and automation. For example, when stock levels reach critical thresholds (Rank A), this data should be immediately visible to the approver in the EPS system without requiring manual verification of IMS data. These improvements are expected to accelerate the approval process and reduce the risk of procurement

BUSINESS PROCESS IMPROVEMENT PLAN IN OPERATIONAL LEAD TIME CONTROL OF SPAREPART BY OPTIMIZING DIGITAL TOOL AND DEALING WITH VENDOR IN PT TACI

Widhi Wahyuniarti and Anton Mulyono Azis

delays. Several interviewees, such as FRM and SPV1, suggested introducing an automatic reminder system for approvers, especially for PRs that require immediate approval. Furthermore, deeper integration, such as the visualization of critical stock data and item lead times, is crucial for supporting faster and more accurate decision-making. In the As-Is flowchart, critical points are seen in the internal approval stage involving multiple approvers. Discrepancies between IMS and EPS data cause delays in the approval process, indicating a gap in system integration that hinders the procurement flow. Therefore, necessary improvements involve enhancing data visualization and automation between both systems, which will expedite approval processes and streamline procurement workflows.

The Role of Supplier Agreements in Procurement

Agreements with suppliers are critical in ensuring the smooth procurement of spare parts at PT TACI. To prevent stock shortages, the company has implemented a forecasting system with suppliers for fast-moving items. This forecasting system enables PT TACI to provide demand predictions to suppliers, allowing them to prepare sufficient stock. However, as noted by SPV2, while forecasting has been implemented for some items, not all suppliers accept these agreements, particularly for non-fast-moving items. This results in reliance on a more reactive ordering process and reduces procurement efficiency. Frequent issues in supplier relationships include untimely deliveries and unavailability of items when needed. Therefore, SPV1 and SPV2 emphasize the importance of reinforcing agreements with suppliers regarding item availability and timely deliveries. As explained by STF, when suppliers fail to deliver on time, PTIC must seek alternative suppliers or coordinate with other teams to address stock shortages. To improve efficiency, PT TACI plans to strengthen long-term agreements with suppliers, especially for routine items with high consumption rates. Interviews with STF and FRM suggest that PT TACI should establish agreements that include commitments to timely deliveries and minimum stock availability for critical items. These agreements are expected to shorten lead times and ensure the availability of necessary items without repeated ordering processes.

The Impact of Technology and Supplier Agreements on Procurement Efficiency

Overall, the implementation of digital technology and stronger agreements with suppliers has positively impacted the efficiency of spare parts procurement at PT TACI. The integration of IMS and EPS allows PT TACI to monitor stock levels more accurately and facilitates faster creation of purchase orders. Additionally, agreements with suppliers related to forecasting and timely deliveries help reduce uncertainty and streamline procurement. However, as indicated in interviews and FGDs, there is still room for improvement, particularly in the integration of data between IMS and EPS, and the enhancement of notification and auto-reminder systems to accelerate the approval process. Additionally, stronger agreements with suppliers regarding item availability and timely deliveries need to be expanded to ensure that PT TACI can meet spare part demands more efficiently. In terms of data integration between IMS and EPS, the issue of data discrepancies can be addressed by improving system integration through the implementation of an API that allows real-time data synchronization between both systems. This step will help reduce procurement errors and enable approvers to make faster and more accurate decisions based on updated data. In conclusion, the utilization of digital technology and stronger supplier agreements has significant potential to enhance procurement efficiency, although several aspects still need improvement to optimize the procurement process further.

Recommendations for Improving Procurement Process and Spare Parts Lead Time Control Based on BPI Approach, Digital Technology Utilization (Web Integration), and Supplier Agreements

Automation of Internal Approval Process

Interviews with SPV1 (June 5, 2025) and FRM (June 10, 2025) revealed that the manual approval process consumes most of the team's time due to frequent follow-ups. To address this, it is recommended to implement auto-approval for routine items (fast-moving items) in which PRs, once agreed upon internally, would be automatically approved if no action is taken within 14 days. Additionally, the system should include escalation notifications to higher-level approvers when deadlines are exceeded, along with urgency visual indicators (red/yellow/green) in the EPS system. FRM also highlighted that the lack of urgency visualization in EPS often causes approval delays, as approvers are unaware of the priority of PRs. To illustrate the difference between the current "As-Is" process and the proposed "To-Be" process, a flowchart can be used. This flowchart compares the current manual process with the proposed automation, which includes auto-approval and direct integration with suppliers. The introduction of this auto-approval system can reduce delays in approval processes, ease monitoring, and increase overall efficiency.

Real-Time Integration Between IMS and EPS

BUSINESS PROCESS IMPROVEMENT PLAN IN OPERATIONAL LEAD TIME CONTROL OF SPAREPART BY OPTIMIZING DIGITAL TOOL AND DEALING WITH VENDOR IN PT TACI

Widhi Wahyuniarti and Anton Mulyono Azis

Interviews with SPV2 (June 17, 2025) and FRM (June 10, 2025) revealed that the lack of integration between IMS and EPS creates difficulties in monitoring stock during the approval process. Employees must manually open both systems, which slows down decision-making. Therefore, it is recommended to integrate the systems via an API to synchronize stock data, PR status, and urgency classifications (Rank A–C) in real-time. The FGD on June 20, 2025, emphasized the need for a centralized dashboard and a minimum stock auto-reminder feature to expedite procurement follow-up. The previously displayed flowchart illustrating procurement progress control is highly relevant for supporting this recommendation. The flowchart illustrates the current manual process used in monitoring procurement progress, where data is filtered and processed manually via Excel. This manual system can be replaced with a centralized dashboard that provides real-time access to procurement data, allowing faster and more efficient monitoring.

Enhancement of Tracking and Forecasting Systems

During interviews with STF (June 18, 2025) and SPV1 (June 5, 2025), it was noted that manual forecasting using Excel often results in inaccuracies and delays. It is recommended to create a real-time tracking system for deliveries, displayed in EPS, similar to e-commerce tracking systems. Additionally, spare part forecasting should be digitized using historical data and production plans, with results directly sent to suppliers to support order fulfillment. SPV1 also recommended establishing long-term agreements with suppliers for Rank A items to guarantee stock availability and timely delivery. The example of an email forecast sent to suppliers illustrates how manual forecasting is still carried out using Excel, which is prone to errors and delays. To improve efficiency, this forecasting system should be replaced with a more accurate and efficient digital system, allowing for direct and automatic communication with suppliers based on estimated item needs.

Simplification of Processes for Routine Items

Based on SPV1's recommendation on June 5, 2025, and the agreement in the FGD on June 20, 2025, the process for routine items should be simplified through cumulative PRs every 6–12 months, with POs being directly issued without further approval. Additionally, the IMS system can be set to automatically generate PRs when stock reaches the Order Point (OP). This solution is expected to cut approval time by up to 50% and significantly reduce the procurement workload.

Figure 9
To-Be Spare Parts Procurement Flowcharts

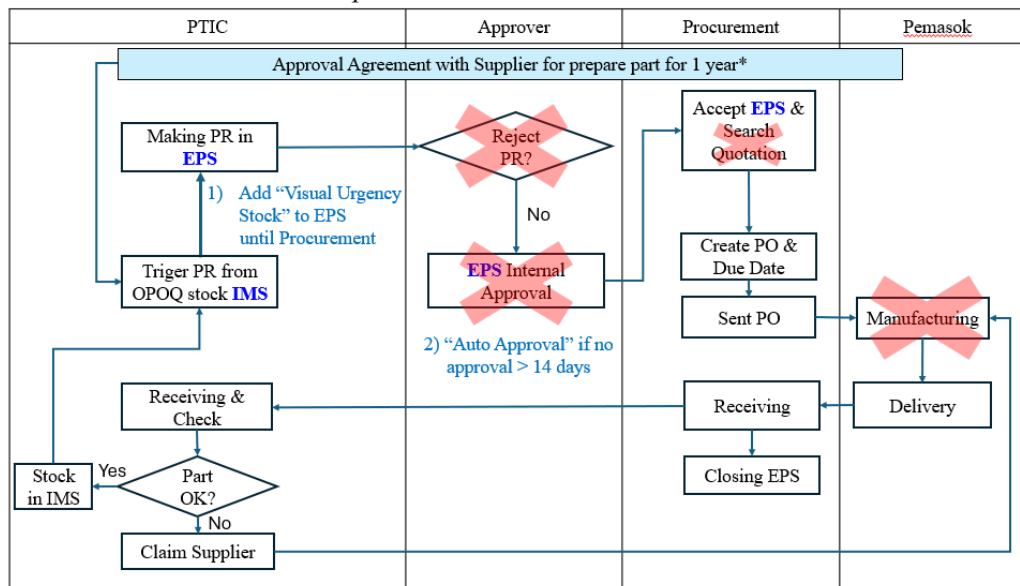

□ Additional Activity

✗ Delete Activity

Source: PT TACI, secondary data processed (2025)

The figure above shows the transition from a manual process to automation, including cumulative PRs, automatic validation, and reduction of unnecessary approval steps. This change is expected to speed up approval times and reduce the procurement team's workload, thereby enhancing overall efficiency in routine item procurement.

Creation of SOPs and Training

FRM (June 10, 2025) noted that delays in the process were often caused by users' insufficient understanding of the IMS and EPS systems. Therefore, it is essential to create standardized Standard Operating Procedures (SOPs) that cover procurement workflows, handling of critical items, and communication with suppliers. Regular training for the PTIC team, approvers, and procurement staff is expected to enhance understanding and optimize the adoption of the digital systems. Based on the interviews, FGDs, and analysis of the spare parts procurement process at PT TACI, it was found that the primary obstacles in lead time control stem from slow manual processes, lack of system integration, and suboptimal user understanding of the systems. To address these issues, improvements are recommended through the BPI approach with the support of digital technology and supplier agreements. These recommendations include automating the approval process, real-time integration between IMS and EPS, digitizing tracking and forecasting systems, simplifying procurement workflows for routine items, strengthening readiness part in supplier, and developing SOPs and user training. Implementing these steps is expected to improve efficiency, reduce lead time by up to 50%, and ensure faster and more reliable spare part availability.

Discussion

This study aims to identify the obstacles in the spare parts procurement process at PT TACI and provide recommendations for improvement based on the Business Process Improvement (BPI) approach, the utilization of digital technology, and closer collaboration with suppliers. The findings suggest that while the spare parts procurement process is well-structured, several issues still hinder operational efficiency and effectiveness. One of the main obstacles found is the lengthy internal approval process. (Collier & Evans, 2021), in their Operations Management Theory, explain that process design that focuses on efficiency is crucial for minimizing lead time. This finding aligns with Andrašec et al., (2024), which highlights that simplifying approval workflows is an essential step in BPI to enhance efficiency. This study recommends implementing automated approval processes based on automatic prioritization, as proposed by Pradnyana & Listartha, (2021), who use SLA-based prioritization to expedite approval processes. Additionally, Immawan, (2021) suggest using Value Stream Mapping (VSM) to identify non-value-added activities and optimize process time. Therefore, PT TACI can implement an automatic reminder system with urgency indicators (such as red, yellow, green) to accelerate decision-making, which aligns with the principles of BPI by Harrington

Another challenge faced by PT TACI is the reliance on manual systems for critical stock control, which hinders fast decision-making. (Krajewski & Malhotra, 2022), in Supply Chain Management Theory, emphasize the importance of efficient inventory management for the smooth flow of goods in the supply chain. Gebisa, (2023) further supports this, showing that real-time information sharing between companies and suppliers can reduce operational costs and improve supply chain efficiency. As outlined by Junaidi et al., (2024), the use of ERP systems and automation to reduce manual tasks can significantly enhance operational efficiency and speed up decision-making. Therefore, PT TACI should improve the integration of its IMS and EPS systems to enhance inventory management, as highlighted by Utomo et al., (2021), who demonstrated how ERP implementation enhances process efficiency at PT Bank Mantap.

Regarding availability of parts at the supplier, PT TACI experienced constraints related to goods that were not fully available at the supplier. Theory of Agreement with Suppliers (Monczka et al., 2015 in Saragih, (2024) states that a clear and transparent relationship with suppliers is very important to reduce the occurrence and ensure that both parties understand the terms of cooperation. PT TACI must pay more attention to procedures for ensuring stock availability at suppliers in accordance with agreed standards. Adirektawon et al., (2024) research which discusses the implementation of Vendor-Managed Inventory (VMI) also shows that close relationships with suppliers can improve inventory maintenance, speed up lead times, and ensure the availability of goods at suppliers. In this case, PT TACI can implement tighter agreements with suppliers to reduce unavailability of goods and time-consuming procurement activities. This study also identifies discrepancies between IMS and EPS that delay decision-making. Chengguo et al., (2021) show that system discrepancies can reduce operational efficiency in supply chain management. So, by integrating the IMS and EPS systems more effectively will minimize procurement errors and speed up decision-making.

Supplier delays are another significant issue. The reliance on emergency requests that bypass formal channels causes uncertainty in deliveries. Adirektawon et al., (2024) highlights that implementing forecasting based on

BUSINESS PROCESS IMPROVEMENT PLAN IN OPERATIONAL LEAD TIME CONTROL OF SPAREPART BY OPTIMIZING DIGITAL TOOL AND DEALING WITH VENDOR IN PT TACI

Widhi Wahyuniarti and Anton Mulyono Azis

historical data and strengthening relationships with suppliers through VMI can improve the flow of goods and reduce dependence on emergency orders. This is supported by Wood et al., (2022), who emphasize the importance of long-term agreements with suppliers to optimize procurement and reduce uncertainty in deliveries. Additionally, Yan et al., (2025), in their research on supplier contract selection, explain that choosing the right contract strategy between suppliers can expedite procurement by reducing dependence on reactive ordering processes. Overall, PT TACI needs to strengthen the use of web-based digital systems to accelerate the procurement process and enhance data transparency. Research by Gebisa, (2023) and Pradnyana & Listartha, (2021) shows that digital systems can synchronize data in real-time and speed up decision-making, which aligns with the principles of BPI. Furthermore, the research by Maulana, (2024), which develops a BPI and Balanced Scorecard (BSC) framework for process analysis and modeling, demonstrates that combining BPI and BSC can provide a clear framework for managing process efficiency, which can also be applied to optimize spare parts procurement at PT TACI.

The study by Dewi et al., (2023) on the analysis and improvement of the payment system at University X using BPI can be adapted by PT TACI to redesign the procurement process more efficiently. By utilizing BPMN and other tools like Bizagi Modeler, PT TACI can redesign the procurement process to eliminate non-value-added activities, in line with BPI principles outlined by Harrington. From the findings, it can be concluded that PT TACI needs to implement several improvement recommendations, including: (1) Automating the approval process and setting up automatic reminders based on urgency to expedite decision-making, (2) Integrating IMS and EPS systems to enhance inventory management, (3) Improving tracking dan *forecasting* system, (4) Strengthening long-term agreements with suppliers and simplify procurement process, and (5) Implementing web-based systems to improve efficiency and transparency in spare parts procurement. By implementing these recommendations, PT TACI can improve operational efficiency, reduce lead time, and ensure the availability of spareparts. This study underscores the importance of integrating digital systems, closer collaboration with suppliers, and applying BPI to optimize the spare parts procurement process at the company.

Conclusion, Limitation, and Future Research

This study concludes that although the spare parts procurement process at PT TD Automotive Compressor Indonesia (PT TACI) is structurally well-defined and supported by Inventory Management System (IMS) and E-Purchasing System (EPS), several inefficiencies remain that hinder operational effectiveness. Key challenges identified include delays caused by multi-level internal approvals, reliance on manual data handling, and difficulties in sourcing non-routine items. These constraints contribute to extended lead times and reduced responsiveness across the procurement lifecycle.

Systemic limitations such as the lack of real-time integration between IMS and EPS and the absence of long-term supplier agreements further complicate timely decision-making and delivery assurance. Improvements through Business Process Improvement (BPI) are essential, particularly in streamlining data workflows, automating routine approvals, enhancing supplier coordination, and implementing urgency-based visualization tools. These adjustments are expected to increase transparency, shorten procurement cycles, and support organizational continuity. Despite yielding valuable insights, this research has limitations. The study was conducted within a single company, focusing only on the internal structure of spare parts procurement. Broader validation across industries or comparative analysis with other firms was beyond the scope. Additionally, technical access to system architecture was limited, and the reliance on qualitative interviews may constrain generalizability. Future research should explore the role of advanced digital technologies such as Artificial Intelligence (AI), Blockchain, or predictive analytics in further enhancing procurement integration and decision-making accuracy. Comparative studies involving multiple manufacturing organizations or sectors could also provide a more comprehensive understanding of lead time management best practices. Furthermore, quantitative assessments of lead time reductions or cost savings post-implementation would offer measurable evidence to support strategic procurement reform.

Author contribution

Widhi Wahyuniarti: Conceptualization, Lead Researcher, Data Collection, Methodology, Writing of the Paper, Data Analysis, Editing.

Anton Mulyono Azis: Supervisor, Editor, and Reviewer.

Declaration of interest

The authors declare that they have no known competing financial interests or personal relationships that could have appeared to influence the work reported in this paper

REFERENCES

- Adirektawon, S., Theeraroungchaisri, A., & Sakulbumrungsil, R. C. (2024). Efficiency of Inventory in Thai Hospitals: Comparing Traditional and Vendor-Managed Inventory Systems. *Logistics*, 8(3), 89.
- Alamsyah, A., Hakim, N., & Hendayani, R. (2022). Blockchain-based traceability system to support the Indonesian halal supply chain ecosystem. *Economies*, 10(6), 134.
- Andrašec, E. K., Urh, B., Roblek, M., & Kern, T. (2024). An analysis of methods and techniques used for business process improvement. *Organizacija*, 57(2), 165–184.
- Babičković, B. P., Vojinović, Ž., Leković, B., Cvijanović, D., Sedlak, O., & Ćirić, Z. (2020). Business process improvement of the wastewater treatment: reducing the risk of environmental pollution. *Serbian Journal of Management*, 15(1), 127–142.
- Chengguo, Jang, G., Jiuxian, Z., & Shilin, Q. (2021). Research on Integration of Information System in Customs Supervision Warehouse Based on Business Process Improvement. *International Workshop on Computer Science and Engineering*, 2(3), 978–971. <https://doi.org/DOI: 10.18178/wcse.2021.06.007>
- Collier, D. A., & Evans, J. R. (2021). *Operations and supply chain management*. Cengage Learning, Inc.
- Dewi, Nirmala, Putra, & Sudana, (2023). Analisis dan Perbaikan Proses Bisnis Sistem Terintegrasi Pembayaran Uang Kuliah dengan Metode Business Process Improvement (BPI) pada Universitas X. *Jurnal Teknologi Informasi Dan Ilmu Komputer*, 10(2), 411–420.
- Gebisa, D. (2023). The impact of information sharing and inventory management practices on firms' performance in supply chain practices. *Gadjah Mada International Journal of Business*, 25(2), 199–225.
- Hendayani, R., & Febrianta, M. Y. (2020). Technology as a driver to achieve the performance of family businesses supply chain. *Journal of Family Business Management*, 10(4), 361–371.
- Immawan, T. (2021). Business process improvement in brown sugar industry in Kudus regency. *Journal of Physics: Conference Series*, 1764(1), 12182.
- Irmayani, Wujarso, R., Julyanthry, J., & Silalahi, M. (2022). Buku Ajar Supply Chain Management (in Retail Setting). *Journal of Management*, 2(3).
- Junaidi, K., Chalil, D., & Wibowo, R. P. (2024). ERP Implementation Success: Impact of Critical Factors and Employee Diversity at PT. ALAM Palm Plantation in North Sumatra. *Revista de Gestão Social e Ambiental*, 3(2), 131.
- Krajewska, A., & Krajewski, S. (2020). The labor market in poland and the social responsibility of the state and business: Comparative aspects. *Comparative Economic Research. Central and Eastern Europe*, 23(1), 93–109.
- Krajewski, & Malhotra, M. K. (2022). *Operations management: Processes and supply chains*. Pearson.
- Maulana, Y. M. (2024). Kerangka Kerja Analisis dan Pemodelan Pada Proses Bisnis Berdasarkan BPI Dan BSC. *Jurnal Teknologi Informasi Dan Ilmu Komputer*, 11(2), 349–356.
- Pradnyana, I. M. A., & Listartha, I. M. E. (2021). Business process improvement design of complaints on technical information system problems using the business process improvement method. *Journal of Physics: Conference Series*, 1810(1), 12031.
- Prasetio, A., & Muchnita, A. (2022). The role website quality, credit card, sales promotion on online impulse buying behavior. *Jurnal Manajemen*, 26(3), 424–448.
- Saragih, D. R. U. (2024). *Manajemen strategik dan keberlanjutan bisnis*. Mega Press Nusantara.
- Sari, S. P., Handriansyah, A. E., Anwar, W., Suryaningsih, N., Jubaedah, E., Rustandi, R., Widiarti, T., Astuti, I. P., Alirejo, M. S., & Mulyati, C. (2024). *Operations & Supply Chain Management*. Pradina Pustaka.
- Sholihah, N. A., Abbas, I., Awaru, A. O. T., Djamdjuri, D. S., Santoso, H. R., Surni, Khoiruddin, S., & Jemakmun. (2023). *Metode Penelitian Kualitatif dan Kuantitatif*. Selat Media.
- Sirine, H. (2024). *Manajemen rantai Pasok Adaptif: Teori dan Praktik*. Widina Media Utama.
- Sukmono, R. A. (2021). Buku Ajar Supply Chain Management Theory and Practice. *Umsida Press*, 1–73.
- Sutjiatmo, B. P., Nurkomariyah, S., Tyasti, A. E., & Bani, F. C. D. (2024). Design of customized business process management with implementation in the apparel industry as a solution to achieve operational excellence. *Edelweiss Applied Science and Technology*, 8(4), 709–720.
- Syamil, Ahmad, Subawa, Subawa, Budaya, Indra, Munizu, Musran, Darmayanti, Luh, N., Fahmi, Ainul, M., Wanda, S. S., Murwani, I. A., Utami, F. N., & Dulame, I. M. (2023). *Manajemen Rantai Pasok*. PT. Sonpedia Publishing Indonesia.

BUSINESS PROCESS IMPROVEMENT PLAN IN OPERATIONAL LEAD TIME CONTROL OF SPAREPART BY OPTIMIZING DIGITAL TOOL AND DEALING WITH VENDOR IN PT TACI

Widhi Wahyuniarti and Anton Mulyono Azis

- Tiedemann, F., Wikner, J., & Johansson, E. (2021). Understanding lead-time implications for financial performance: a qualitative study. *Journal of Manufacturing Technology Management*, 32(9), 183–207.
- Unggul Saragih, D. R. (2024). *Manajemen Operasional Strategi dan Praktik Terbaik*. Literasi Nusantara.
- Utomo, S. B., Yuliani, E. W., & Wulandari, N. (2021). Business process improvement (BPI) with enterprise resource planning (ERP) financial & control (FICO) and procurement modules using SAP S/4 HANA to handle non-banking processes in case study: PT bank mantap. *Journal of Physics: Conference Series*, 1807(1), 12004.
- Wood, L. C., Duong, L. N. K., & Wang, J. X. (2022). Business process improvement for sustainable technologies investments in construction: a configurational approach. *Sustainability*, 14(9), 5697.
- Yan, H., Dai, X., Shangguan, L., & Ye, F. (2025). Optimal contract selection considering the entry of a new supplier. *RAIRO-Operations Research*, 59(2), 1067–1098.